

Verdrehgesicherter
pneumatischer
Kurzhubzylinder
Kompakte Baureihe

JDR

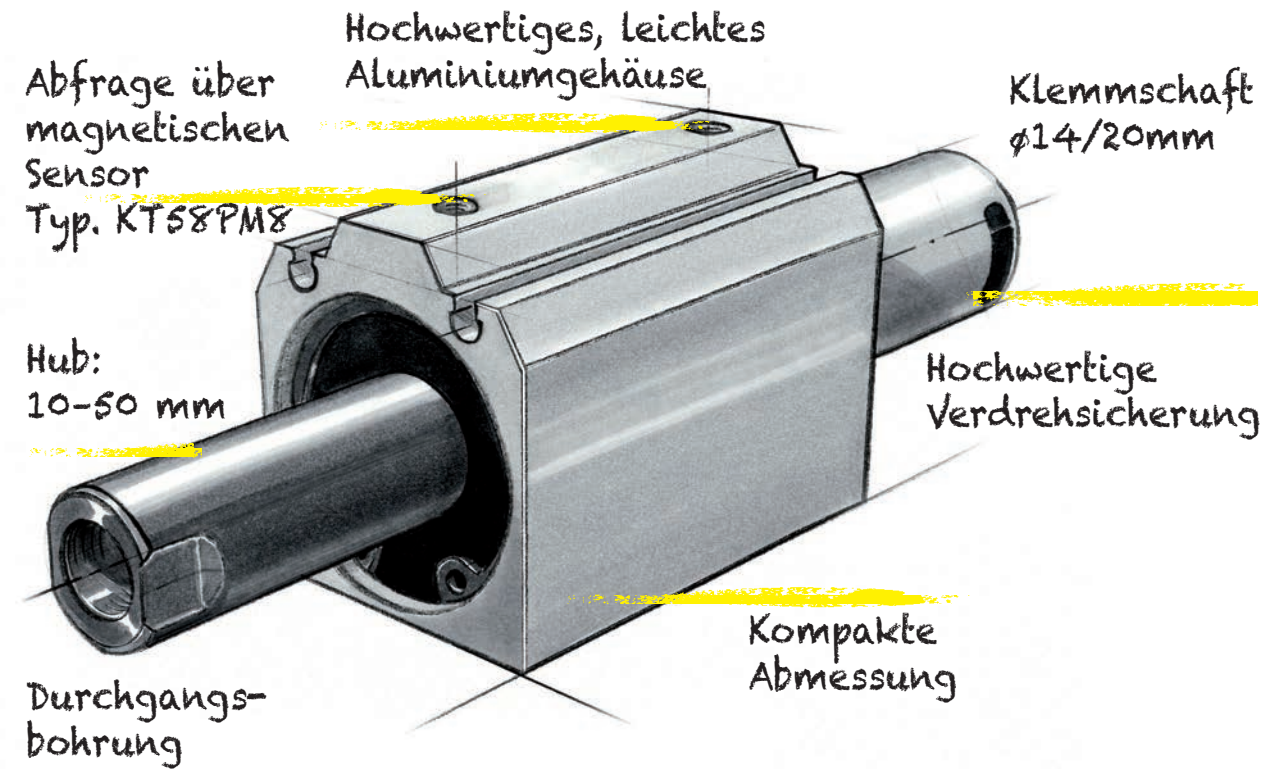

Verdrehgesicherter
pneumatischer
Kurzhubzylinder
Kompakte Baureihe
JDR

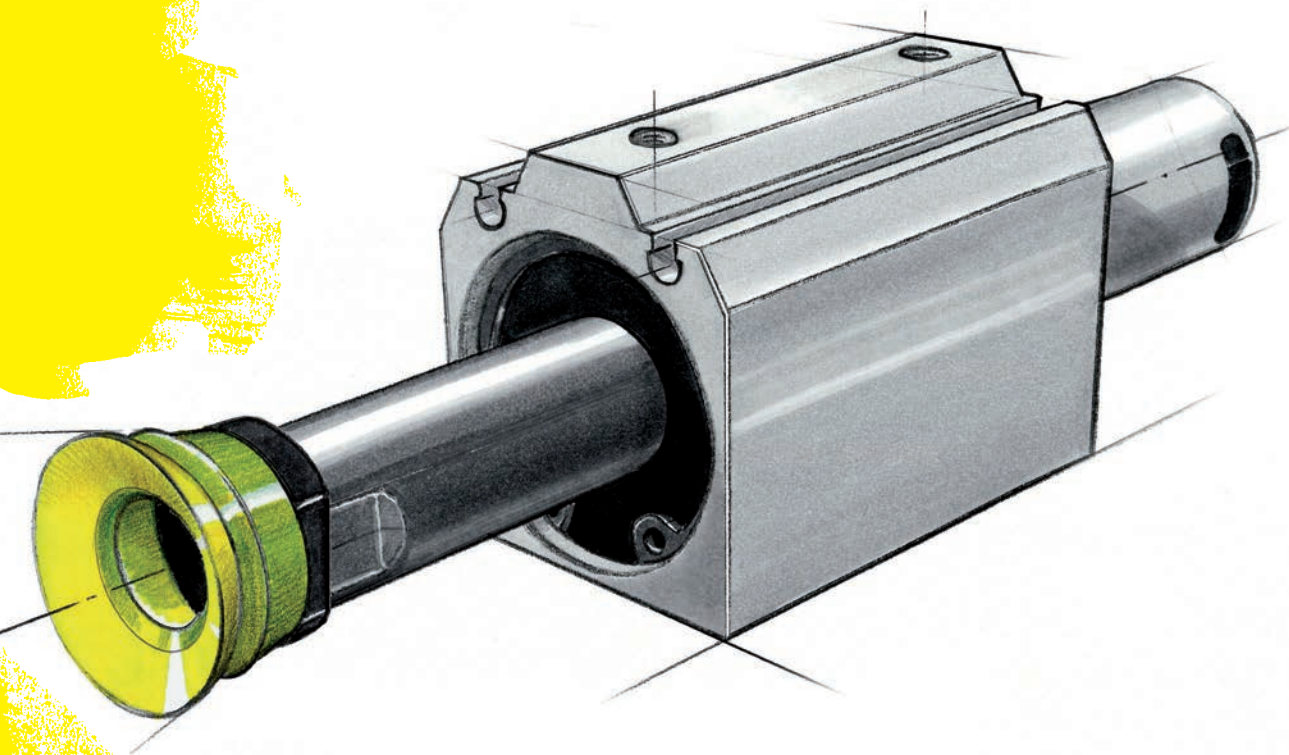

Greif-Technik-Schmid GmbH
Schulze-Delitzsch-Weg 30
89079 Ulm-Wiblingen
fon +49 7 31-8 80 25 60
fax +49 7 31-8 80 25 62
direct +49 179-2 99 20 64
info@gts-p.de

Partner of



FP SERVICES
AUTOMATION



Stand 03.2016
Technische Änderungen
vorbehalten.

fon +49 7 31-8 80 25 60
direct +49 1 79-2 99 20 64
www.gts-p.de
info@gts-p.de

Kompetenz greifbar



Made in Italy!
Nur bei GTS!

Verdrehgesicherter pneumatischer Kurzhubzylinder kompakt



GT.JDR.14

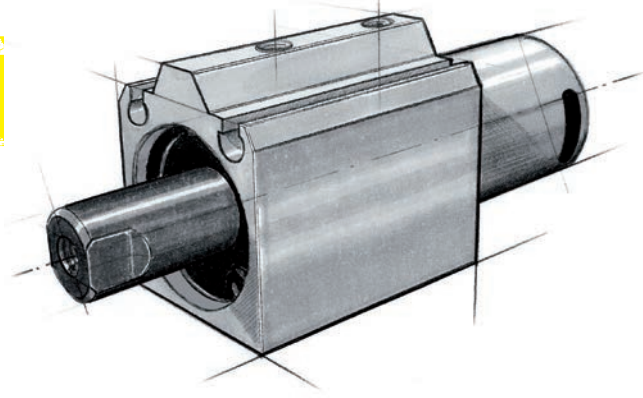

Bestell-Nr.	Klemm- ϕ mm	Hub mm	Anschluss Vakuum/Druckluft	A mm	B mm	C mm	D sw	E mm	Gewicht (g)
GT.JDR.14.10.5	14	10	M5/M5	74,2	24	29	8	19	54
GT.JDR.14.25.5	14	25	M5/M5	119,2	24	29	8	19	76

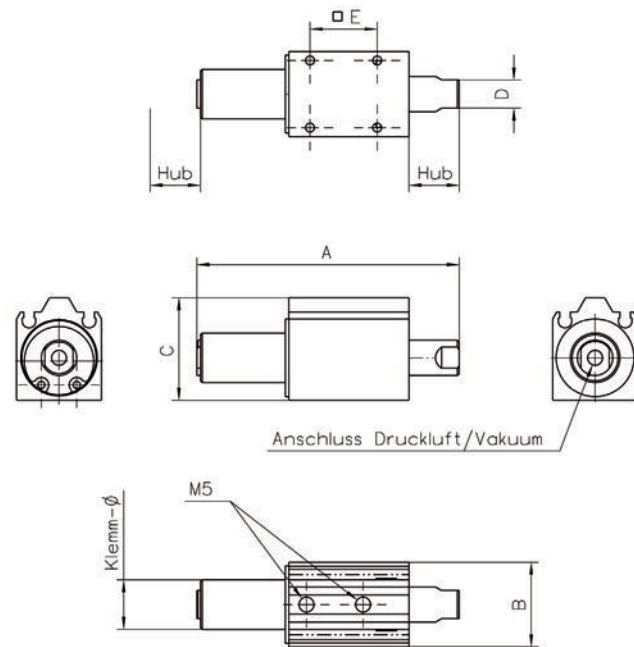

Verdrehgesicherter pneumatischer Kurzhubzylinder kompakt



GT.JDR.20

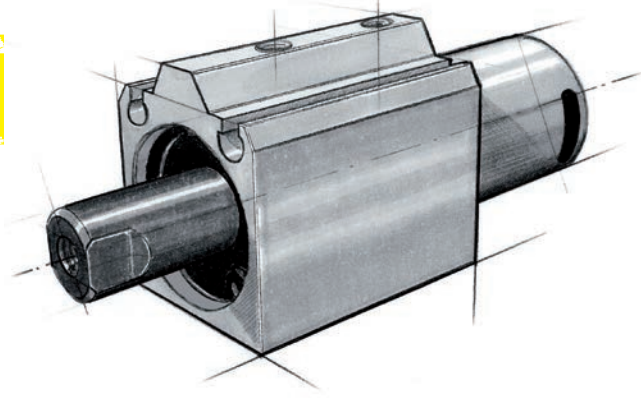

Bestell-Nr.	Klemm- ϕ mm	Hub mm	Anschluss Vakuum/Druckluft	A mm	B mm	C mm	D sw	E mm	Gewicht (g)
GT.JDR.20.10.5	20	10	M5/M5	74,2	24	29	8	19	63

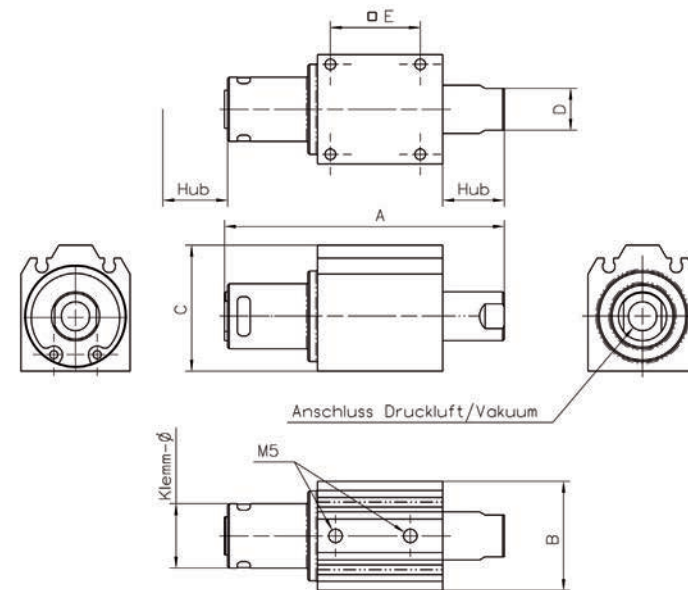

Verdrehgesicherter pneumatischer Kurzhubzylinder kompakt



GT.JDR.30

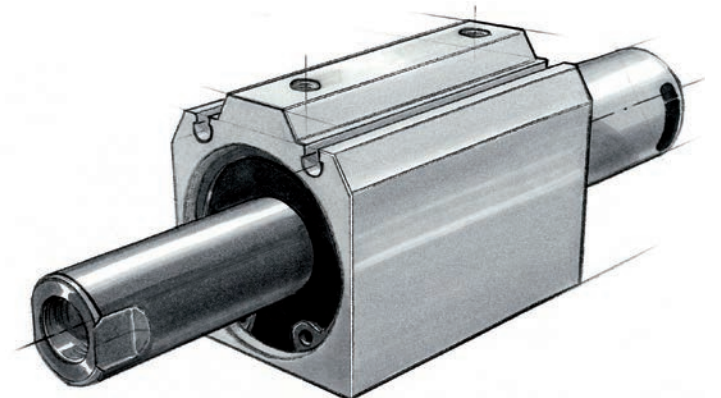

Bestell-Nr.	Klemm- ϕ mm	Hub mm	Anschluss Vakuum/Druckluft	A mm	B mm	C mm	D sw	E mm	Gewicht (g)
GT.JDR.30.15.18	20	15	G1/8 / M5	87,2	34	39	13	28	112
GT.JDR.30.30.18	20	30	G1/8 / M5	130,2	34	39	13	28	150
GT.JDR.30.50.18	20	50	G1/8 / M5	190,2	34	39	13	28	200

